

WOD 30 - 2F

TECHNICAL DATA

- **Flow:** 30 l/min
- **Max setting pressure:** 350 bar
- **Materials:** Steel Body
- **Pilot ratio:** 4:1 (if request 8:1; 11:1)
- **Weight:** (See Table)

- **Note:** Pressure setting must be 30 % higher that pressure induced by the load

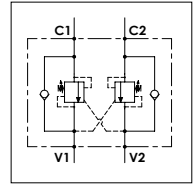

PORTS		
V1 - V2	1/4	3/8
C1 - C2	ø6,5	
DIMENSIONS		
A	45	50
B	94	92
C	29	30
D	28	28
E	8,5	11
Weight (kg)	1,650	1,780

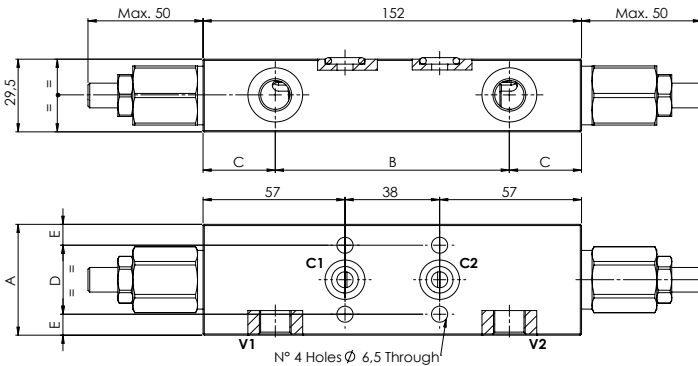

PRESSURE DROP CURVES

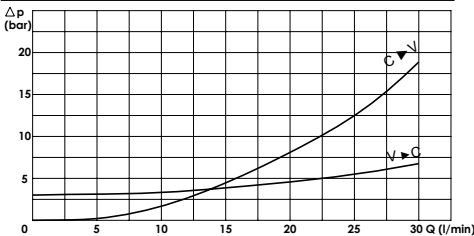

SPRINGS

Code	20			35		
	Adjustable pressure range bar	Pressure increase bar/turn	Standard setting bar	Adjustable pressure range bar	Pressure increase bar/turn	Standard setting bar
4:1	60-210	70	170	80-350	120	280
8:1	60-220	50		100-350	85	
11:1	60-250	90		80-350	150	

ORDERING CODE:

WOD

30

2F

Ports Size:

- 1/4
- 3/8

Springs:

- 20
- 35

Pilot Ratio:

- Omit if 4:1
- 8 = 8:1
- 11 = 11:1

Adjustment if

- Required:
- Omit if not required
- Value