

## WOD 90 - L A

### TECHNICAL DATA

- **Flow:** 90 l/min
- **Max setting pressure:** 250 bar
- **Materials:** Aluminium Body
- **Pilot ratio:** 4:1 (if request 1:1; 8:1; 11:1)
- **Weight:** (See Table)

- **Note:** Pressure setting must be 30 % higher that pressure induced by the load

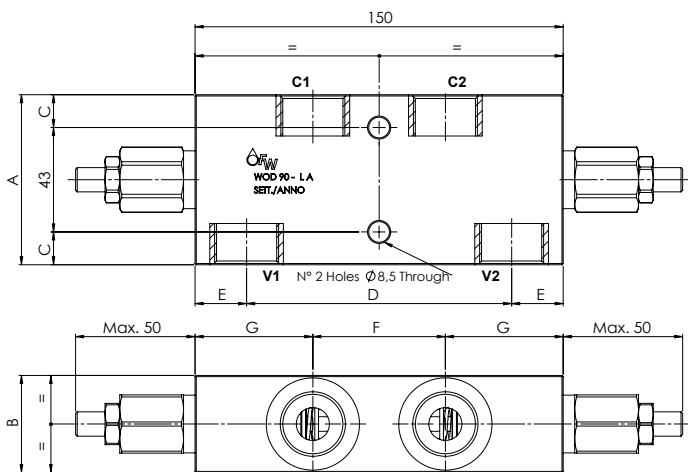
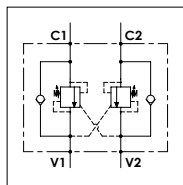

PORTS		
C1 - C2 V1 - V2	1/2	3/4
DIMENSIONS		
A	65	70
B	35	40
C	11	13,5
D	112	108
E	19	21
F	48	54
G	51	48
Weight (kg)	1,250	1,860

### PRESSURE DROP CURVES

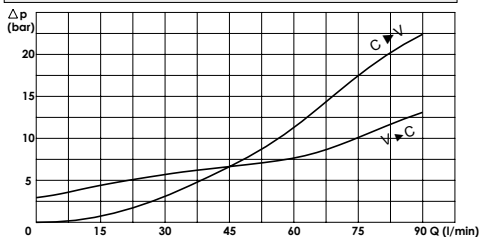

### SPRINGS

Code	20			35		
	Adjustable pressure range bar	Pressure increase bar/turn	Standard setting bar	Adjustable pressure range bar	Pressure increase bar/turn	Standard setting bar
1:1	10-70	15	10	30-200	25	30
4:1	60-210	70	170	80-350	120	280
8:1	60-220	50		100-350	85	
11:1	60-250	90		80-350	150	

## ORDERING CODE:

WOD

90

L

A

**Ports Size:**

- 1/2
- 3/4

**Springs:**

- 20
- 35

**Pilot Ratio:**

- Omit if 4:1
- 1 = 1:1
- 8 = 8:1
- 11 = 11:1

**Adjustment if Required:**

- Omit if not required
- Value