

WODSFC 60 - L

TECHNICAL DATA

- Flow:** 60 l/min
 - Max setting pressure:** 350 bar
 - Materials:** Steel Body
 - Pilot ratio:** 4:1 (if request 1:1; 8:1; 11:1)
 - Weight:** (See Table)
- Note:** - Pressure setting must be 30 % higher that pressure induced by the load.
- Recommended for use with closed center spools.

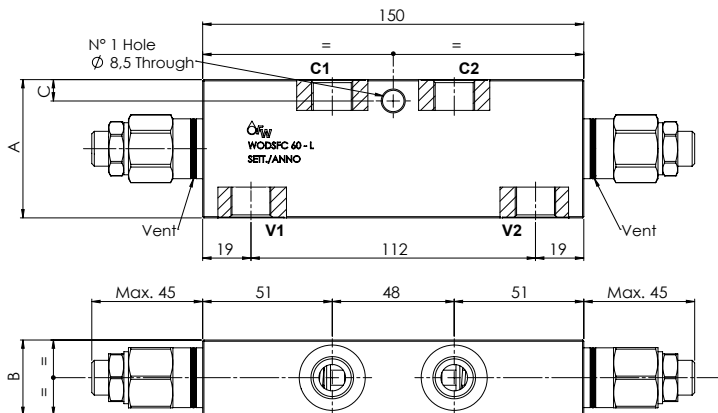
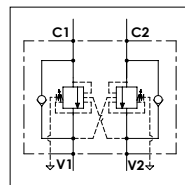

PORTS		
C1 - C2 V1 - V2	3/8	1/2
DIMENSIONS		
A	55	65
B	30	35
C	8,5	11
Weight (kg)	2,000	2,650

PRESSURE DROP CURVES

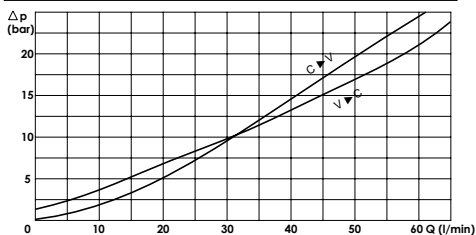

SPRINGS

Code	20			35		
	Adjustable pressure range bar	Pressure increase bar/turn	Standard setting bar	Adjustable pressure range bar	Pressure increase bar/turn	Standard setting bar
1:1	10-70	15	10	30-200	25	30
4:1	60-210	70	170	80-350	120	280
8:1	60-220	50		100-350	85	
11:1	60-250	90		80-350	150	

ORDERING CODE:

WODSFC

60

Ports Size:

- 3/8
- 1/2

L

Springs:

- 20
- 35

Pilot Ratio:

- Omit if 4:1
- 1 = 1:1
- 8 = 8:1
- 11 = 11:1

Adjustment if Required:

- Omit if not required
- Value