

WBD 30 2F

TECHNICAL DATA

- **Flow:** 30 l/min
- **Max working pressure:** 250 bar (350 bar)
- **Cracking pressure:** See table
- **Materials:** Aluminium Body (Steel body if required)
- **Pilot ratio:** See table
- **Weight:** 0,660 kg (1,470 kg)

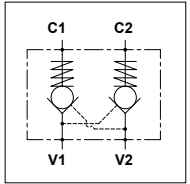
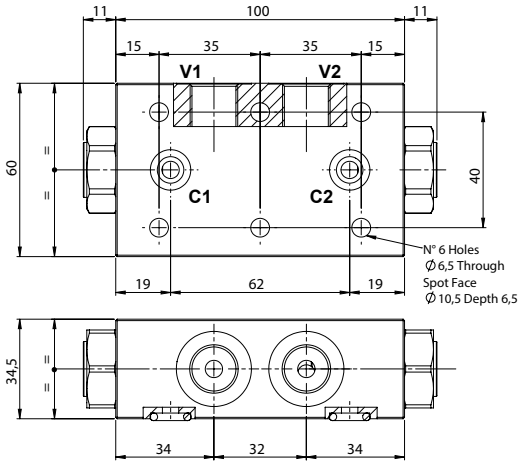

PORTS		
V1 - V2	1/4	3/8
C1 - C2	ø6	
Pilot Ratio	7:1	7:1

PRESSURE DROP CURVES

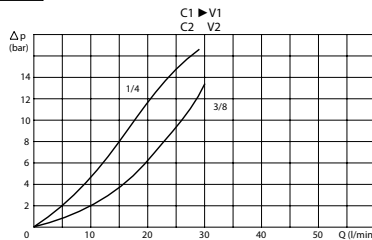
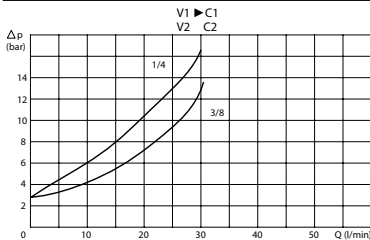

SPRINGS

Code	Cracking pressure bar
Standard	1
2,5	2,5
5	5
10	10

ORDERING CODE

WBD

30

2F

Ports Size:

- 1/4
- 3/8

Material Body:

- Omit if aluminium
- S = Steel

Cracking Pressure:

- Omit if 1 bar
- 2,5 = 2,5 bar
- 5 = 5 bar
- 10 = 10 bar

Seal on Piston:

- Omit if not required
- G = Required