

WMD 25 H

TECHNICAL DATA

- **Flow:** 25 l/min
- **Max setting pressure:** 350 bar
- **Max working pressure:** 250 bar (350 bar)
- **Materials:** Aluminium Body (Steel Body if required)
- **Version:** Poppet Type - Direct Acting
- **Weight:** 0,280 kg (0,570 kg)

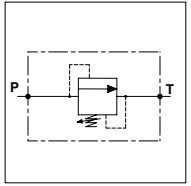

PORTS

P - T	1/4	3/8
-------	-----	-----

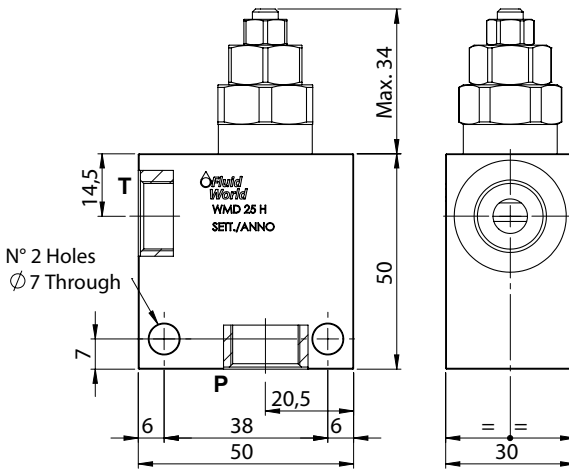

OPTION

(X) Tamber Proof Cap	
-------------------------------	---

PRESSURE DROP CURVES

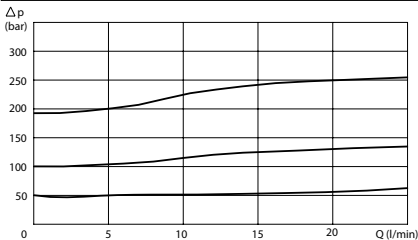

SPRINGS

Code	Adjustable pressure range bar	Pressure increase bar/turn	Standard setting bar
05	20-70	10	20
20	50-180	25	50
35	130-350	60	130

ORDERING CODE



Ports Size:

- 1/4
- 3/8

Material Body:

- Omit if aluminium
- S = Steel

Springs:

- 05
- 20
- 35

Adjustment if Required:

- Omit if not required
- Value
- Value with X