

WMD 40

TECHNICAL DATA

- **Flow:** 40 l/min
- **Max setting pressure:** 350 bar
- **Max working pressure:** 250 bar (350 bar)
- **Materials:** Aluminium Body (Steel Body if required)
- **Version:** Poppet Type - Direct Acting
- **Weight:** 0,400 kg (0,800 kg)

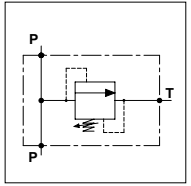

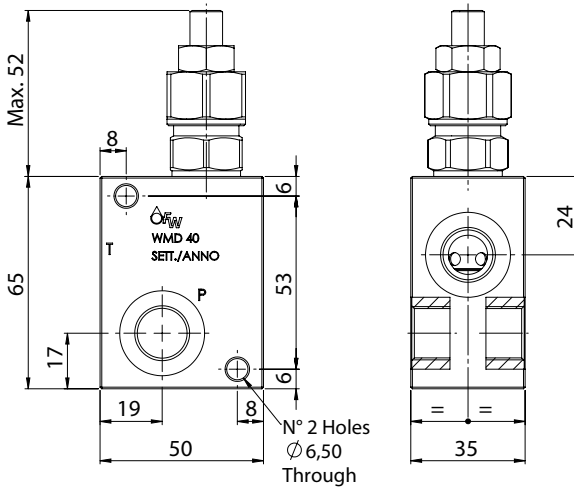

PORTS

P - T	3/8	1/2
-------	-----	-----



REGULATOR

(S) Screw	
(V) Handknob	
OPTION	
(X) Tamber Proof Cap	

PRESSURE DROP CURVES

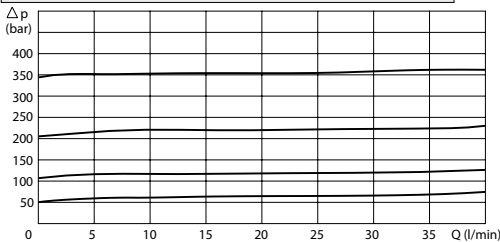

SPRINGS

Code	Adjustable pressure range bar	Pressure increase bar/turn	Standard setting bar
05	5-55	15	5
10	25-110	25	25
20	50-215	50	50
35	100-350	90	100

ORDERING CODE

WMD

40

Ports Size:

- 3/8
- 1/2

Material Body:

- Omit if aluminium
- S = Steel

Type of Regulator:

- S = Screw
- V = Handknob

Springs:

- 05
- 10
- 20
- 35

Adjustment if Required:

- Omit if not required
- Value
- Value with X