

WMD FDB OMM 25

TECHNICAL DATA

- **Flow:** 25 l/min
- **Max setting pressure:** 350 bar
- **Max working pressure:** 250 bar (350 bar)
- **Materials:** Aluminium Body (Steel body if required)
- **Note:** Flangeable on Danfoss motors OMM
- **Weight:** 0,500 kg (0,750 kg)

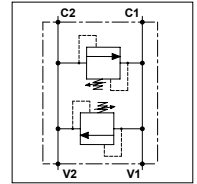

PORTS

C1 - C2	3/8
V1 - V2	

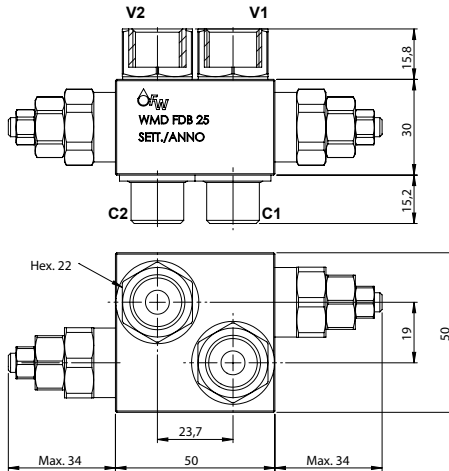

OPTION

Tamper Proof Cap



PRESSURE DROP CURVES

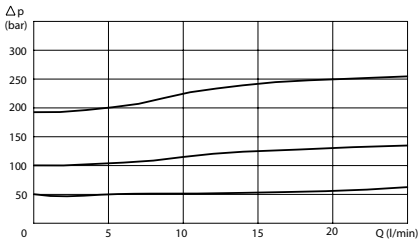

SPRINGS

Code	Adjustable pressure range bar	Pressure increase bar/turn	Standard setting bar
05	20-70	10	20
20	50-180	25	50
35	130-350	60	130

ORDERING CODE

WMD

FDB

OMM

25

3/8

S

Material Body:

- Omit if aluminium
- S = Steel

Springs:

- 05
- 20
- 35

Adjustment if Required:

- Omit if not required
- Value
- Value with X