

WOC 60 S10

TECHNICAL DATA

- **Flow:** 60 l/min
- **Max setting pressure:** 350 bar
- **Materials:** Cartridge in Steel zinc plated
- **Cavity:** FW7803001
- **Installation torque:** 40-45 Nm
- **Weight:** 0,250 kg

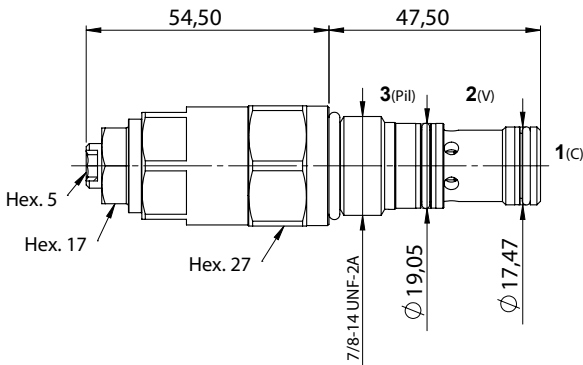
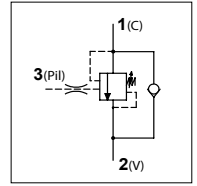

PRESSURE DROP CURVES

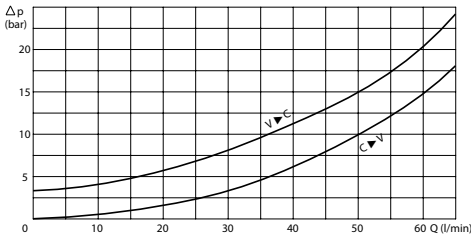

SPRINGS

Code	20			35		
	Adjustable pressure range bar	Pressure increase bar/turn	Standard setting bar	Adjustable pressure range bar	Pressure increase bar/turn	Standard setting bar
4:1	60-220	50	170	80-350	75	280
8:1	60-220	50		80-350	75	

ORDERING CODE

WOC

60

S10

Springs:

- 20
- 35

Pilot Ratio:

- Omit if 4:1
- 8 = 8:1

Adjustment if Required:

- Omit if not required
- Value