

WODFC X 60 - L A BP

TECHNICAL DATA

- **Flow:** 60 l/min
- **Max setting pressure:** 250 bar
- **Materials:** Aluminium Body
- **Pilot ratio:** 4:1 (if request 1:1; 8:1; 11:1)
- **Weight:** 1,570 kg

- **Note:** - Pressure setting must be 30 % higher that pressure induced by the load.
- Recommended for use with closed center spools.

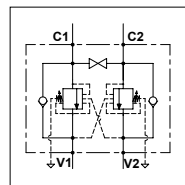

PORTS	
C1 - C2 V1 - V2	3/8

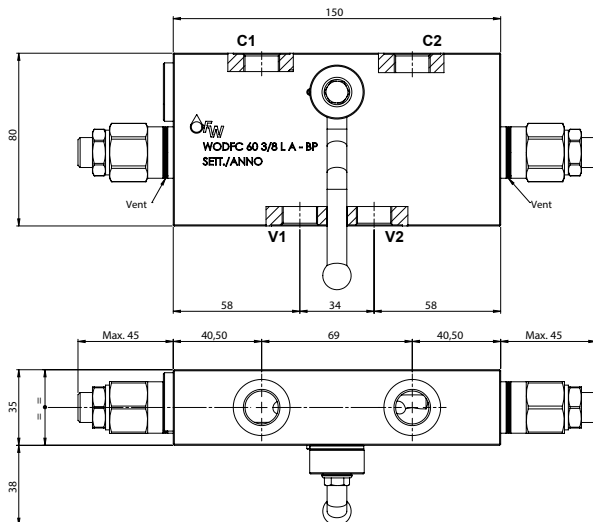

PRESSURE DROP CURVES

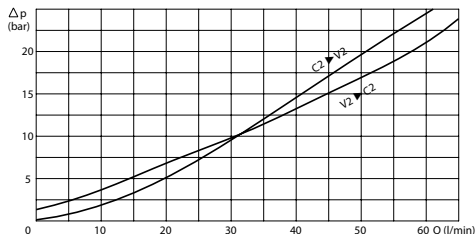

SPRINGS

Code	20			35		
	Adjustable pressure range bar	Pressure increase bar/turn	Standard setting bar	Adjustable pressure range bar	Pressure increase bar/turn	Standard setting bar
1:1	10-70	15	10	30-200	25	30
4:1	60-210	70	170	80-350	120	280
8:1	60-220	50		100-350	85	
11:1	60-250	90		80-350	150	

ORDERING CODE

WODFC X 60 3/8 L A BP

- Springs:** - 20 - 35
- Pilot Ratio:** - Omit if 4:1 - 1 = 1:1 - 8 = 8:1 - 11 = 11:1
- Adjustment if Required:** - Omit if not required - Value