

WODS 60 - L

TECHNICAL DATA

- **Flow:** 60 l/min
 - **Max setting pressure:** 350 bar
 - **Materials:** Steel Body
 - **Pilot ratio:** 4:1 (if request 1:1; 8:1; 11:1)
 - **Weight:** See Table
 - **Note:** Only on request, please contact our sales department
- **Note:** Pressure setting must be 30 % higher that pressure induced by the load

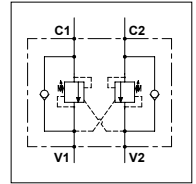

PORTS		
C1 - C2 V1 - V2	3/8	1/2
DIMENSIONS		
A	55	65
B	30	35
C	8,5	11
Weight (kg)	2,000	2,650

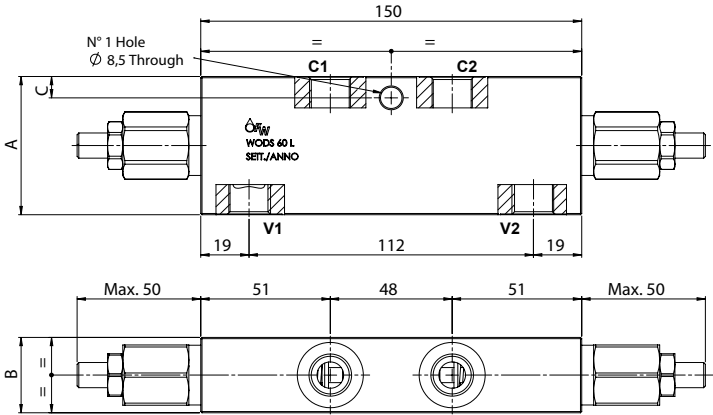

PRESSURE DROP CURVES

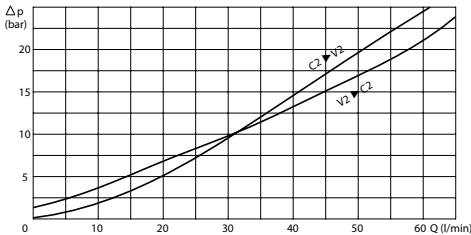

SPRINGS

Code	20			35		
	Adjustable pressure range bar	Pressure increase bar/turn	Standard setting bar	Adjustable pressure range bar	Pressure increase bar/turn	Standard setting bar
1:1	10-70	15	10	30-200	25	30
4:1	60-210	70	170	80-350	120	280
8:1	60-220	50		100-350	85	
11:1	60-250	90		80-350	150	

ORDERING CODE

WODS

60

L

Ports Size:

- 3/8
- 1/2

Springs:

- 20
- 35

Pilot Ratio:

- Omit if 4:1
- 1 = 1:1
- 8 = 8:1
- 11 = 11:1

Adjustment if Required:

- Omit if not required
- Value