

WSD 80

TECHNICAL DATA

- **Flow:** 80 l/min
- **Max setting pressure:** 350 bar
- **Max working pressure:** 250 bar (350 bar)
- **Materials:** Aluminium Body (Steel Body if required)
- **Version:** Poppet Type - Direct Acting
- **Weight:** 1,280 kg (2,680 kg)

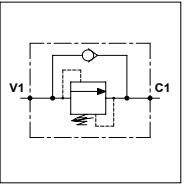



PORTS

C1 - V1	1/2	3/4
---------	-----	-----

SPRINGS

Code	Adjustable pressure range bar	Pressure increase bar/turn	Standard setting bar
05	5-55	5	5
10	25-250	12	25
25	130-350	30	130

REGULATOR

(S) Screw	
(V) Handknob	
OPTION	
(X) Tammer Proof Cap	

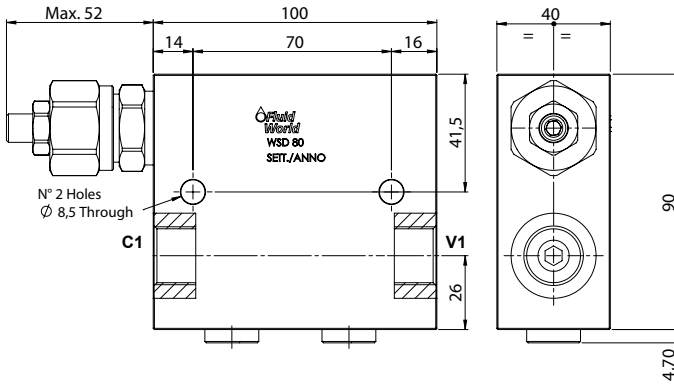

PRESSURE DROP CURVES

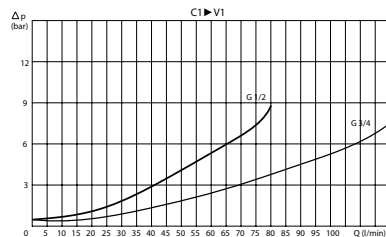
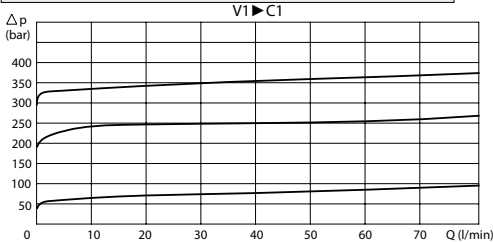

ORDERING CODE

WSD

80

Ports Size:

- 1/2
- 3/4

Material Body:

- Omit if aluminium
- S = Steel

Type of Regulator:

- S = Screw
- V = Handknob

Springs:

- 05
- 10
- 25

Adjustment if Required:

- Omit if not required
- Value
- Value with X