

WUC C 30

TECHNICAL DATA

- **Flow:** 30 l/min
- **Max working pressure:** 350 bar
- **Materials:** Cartridge in Steel Zinc Plated
- **Version:** Poppet Type
- **Cavity:** FW7802100
- **Installation torque:** 40-45 Nm
- **Weight:** 0,100 kg

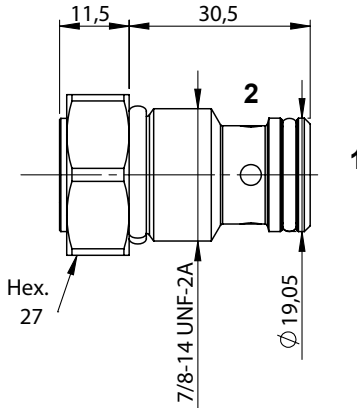
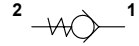

PRESSURE DROP CURVES

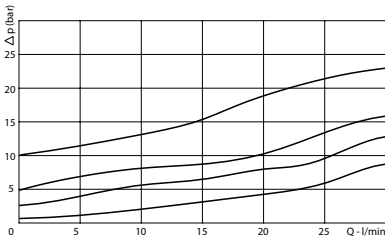

SPRINGS

Code	Cracking pressure bar
Standard	1
2,5	2,5
5	5
10	10

ORDERING CODE

WUC

C

30



Opening Pressure:

- Omit if 1 bar
- 2,5 = 2,5 bar
- 5 = 5 bar
- 10 = 10 bar